

Description

The LMAK40N10 uses advanced trench technology to provide excellent $R_{DS(ON)}$, low gate charge and operation with gate voltages as low as 4.5V. This device is suitable for use as a Battery protection or in other Switching application.

General Features

$V_{DS} = 100V$ $I_D = 40A$

$R_{DS(ON)} < 20m\Omega @ V_{GS}=10V$

Application

Consumer electronic power supply

Motor control

Synchronous-rectification

Isolated DC

Dimensions TO-252

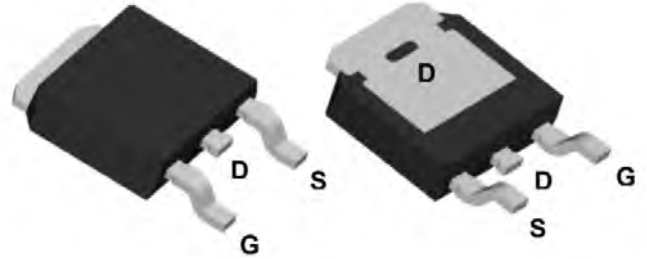

Pin Configuration

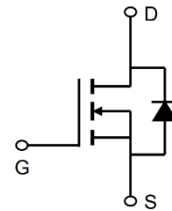

Package Marking and Ordering Information

Product ID	Pack	Marking	Qty(PCS)
LMAK40N10	TO-252	APG40N10D XXX YYYY	2500

Absolute Maximum Ratings ($T_C=25^\circ\text{C}$ unless otherwise noted)

Symbol	Parameter	Rating	Units
V_{DS}	Drain source voltage	100	V
V_{GS}	Gate source voltage	± 20	V
I_D	Continuous drain current ¹⁾ , $T_C=25^\circ\text{C}$	40	A
I_D , pulse	Pulsed drain current ²⁾ , $T_C=25^\circ\text{C}$	120	A
P_D	Power dissipation ³⁾ , $T_C=25^\circ\text{C}$	71	W
EAS	Single pulsed avalanche energy ⁵⁾	57	mJ
Tstg, T_j	Operation and storage temperature	-55 to 150	$^\circ\text{C}$
$R_{\theta JC}$	Thermal resistance, junction-case	1.76	$^\circ\text{C/W}$
$R_{\theta JA}$	Thermal resistance, junction-ambient ⁴⁾	62	$^\circ\text{C/W}$

Electrical Characteristics (T_c=25°C unless otherwise noted)

Symbol	Parameter	Test condition	Min.	Typ.	Max.	Unit
BVDSS	Drain-source breakdown voltage	V _{GS} =0 V, I _D =250 μA	100	107		V
VGS(th)	Gate threshold voltage	V _{DS} =V _{GS} , I _D =250 μA	1.2	1.5	2.5	V
RDS(ON)	Drain-source on-state resistance	V _{GS} =10 V, I _D =10 A		13.8	20.0	mΩ
RDS(ON)	Drain-source on-state resistance	V _{GS} =4.5 V, I _D =7 A		17.4	26.0	mΩ
IGSS	Gate-source leakage current	V _{GS} =±20 V			±100	nA
IDSS	Drain-source leakage current	V _{DS} =100 V, V _{GS} =0 V			1	uA
Ciss	Input capacitance	V _{GS} =0 V, V _{DS} =50 V, f=100 kHz		1003.9		pF
Coss	Output capacitance			185.4		pF
Crss	Reverse transfer capacitance			9.8		pF
td(on)	Turn-on delay time	V _{GS} =10 V, V _{DS} =50 V, R _G =10 Ω, I _D =5 A		16.6		ns
t _r	Rise time			3.8		ns
td(off)	Turn-off delay time			75.5		ns
t _f	Fall time			46		ns
Q _g	Total gate charge	I _D =5 A, V _{DS} =50V, V _{GS} =10V		16.2		nc
Q _{gs}	Gate-source charge			2.8		nc
Q _{gd}	Gate-drain charge			4.1		nc
Vplateau	Gate plateau voltage			3		V
I _s	Diode forward current	V _{GS} <V _{th}		30		A
ISP	Pulsed source current			90		A
trr	Reverse recovery time	I _S =1A, di/dt=100 A/μs	49			ns
Q _{rr}	Reverse recovery charge		61.8			nc
Irrm	Peak reverse recovery current		2.4			A

Note :

- 1、 Calculated continuous current based on maximum allowable junction temperature.
- 2、 Repetitive rating; pulse width limited by max. junction temperature.
- 3、 Pd is based on max. junction temperature, using junction-case thermal resistance.
- 4、 The value of R_{θja} is measured with the device mounted on 1 in 2 FR-4 board with 2oz. Copper, in a still air environment with T_a=25 °C.
- 5、 V_{DD}=50 V, R_G=25 Ω, L=0.3 mH, starting T_J=25 °C.

Typical Characteristics

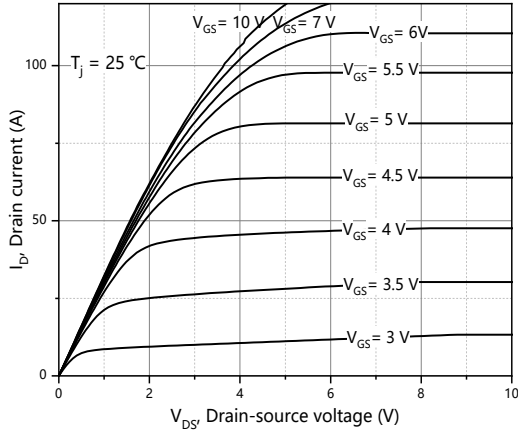

Figure 1, Typ. output characteristics

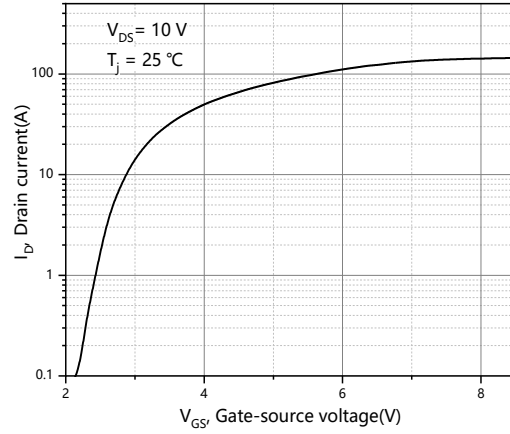

Figure 2, Typ. transfer characteristics

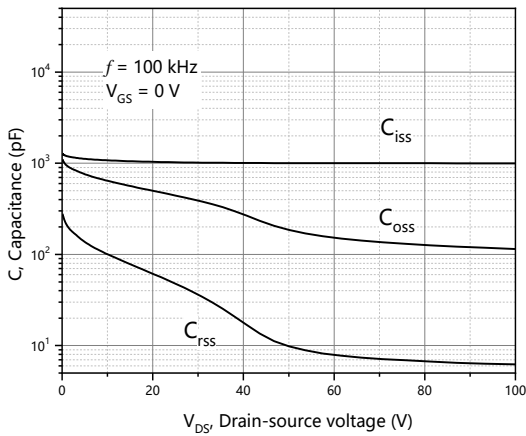

Figure 3, Typ. capacitances

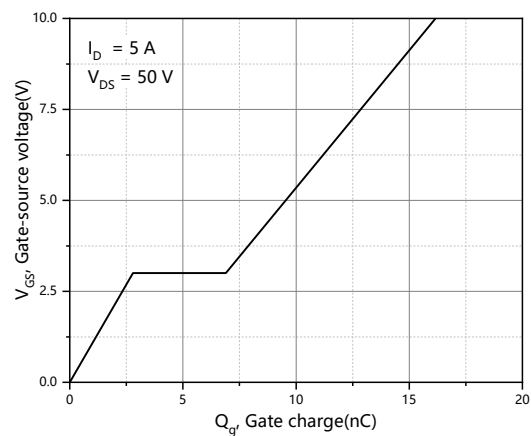

Figure 4, Typ. gate charge

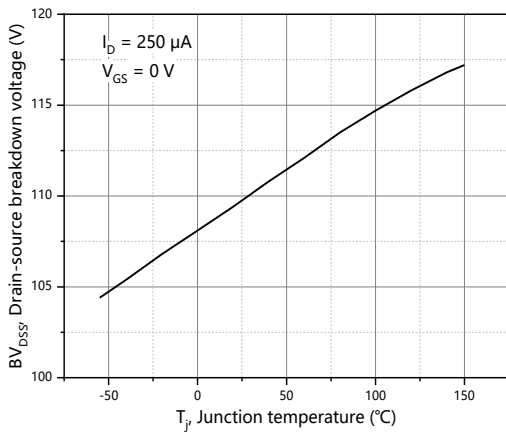

Figure 5, Drain-source breakdown voltage

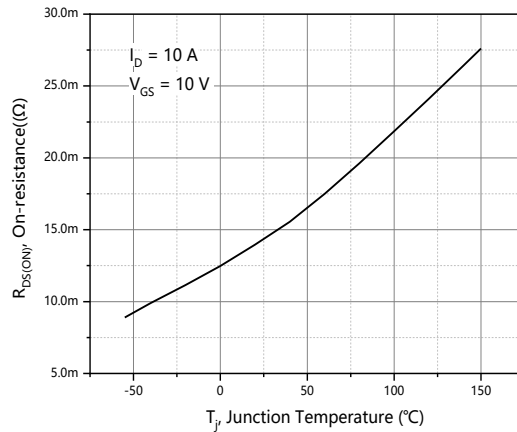

Figure 6, Drain-source on-state resistance

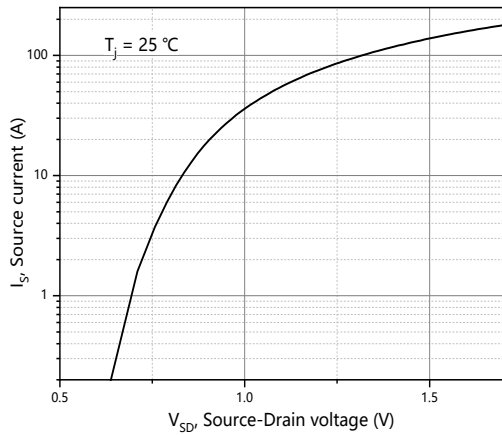

Figure 7, Forward characteristic of body diode

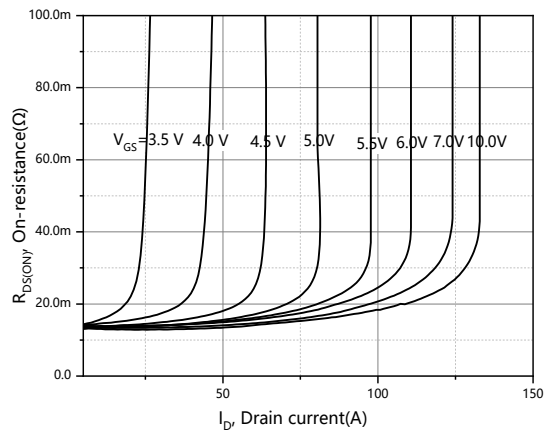

Figure 8, Drain-source on-state resistance

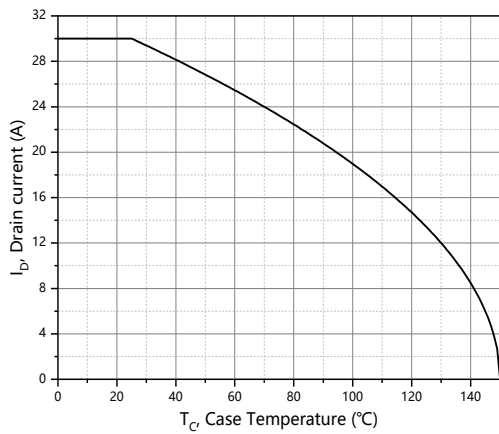

Figure 9, Drain current

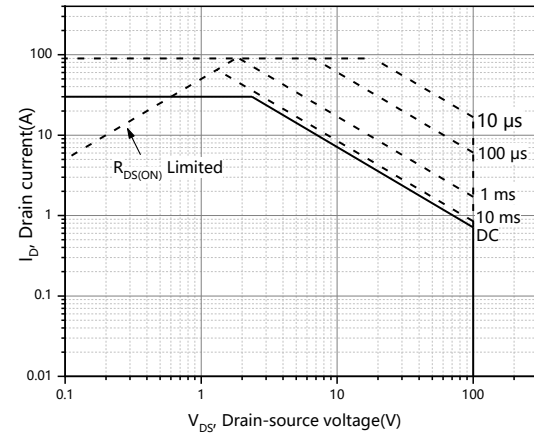

Figure 10, Safe operation area $T_C=25\text{ °C}$

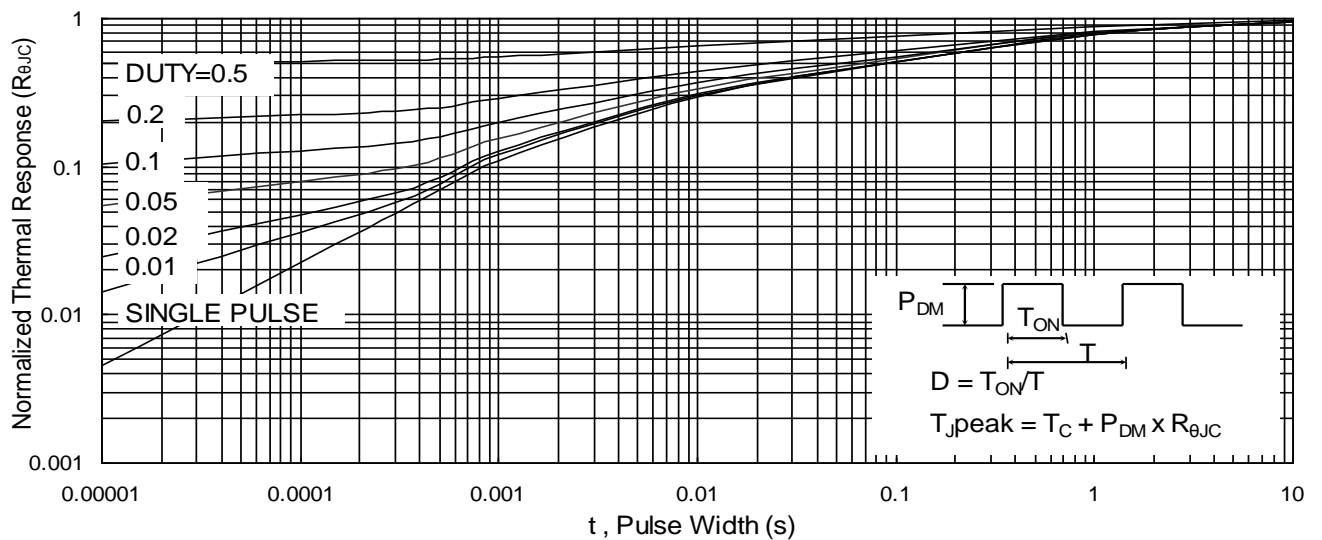
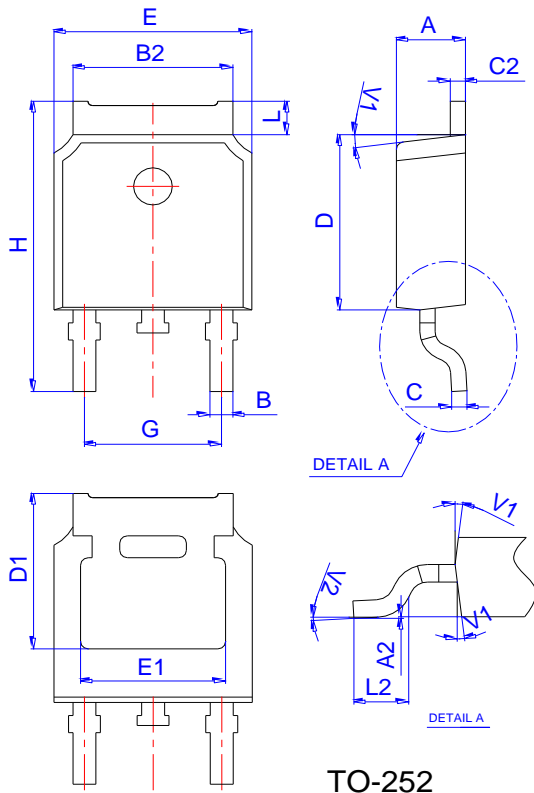

Fig11. Normalized Maximum Transient Thermal Impedance

Package Mechanical Data: TO-252



Ref.	Dimensions					
	Millimeters			Inches		
	Min.	Typ.	Max.	Min.	Typ.	Max.
A	2.10		2.50	0.083		0.098
A2	0		0.10	0		0.004
B	0.66		0.86	0.026		0.034
B2	5.18		5.48	0.202		0.216
C	0.40		0.60	0.016		0.024
C2	0.44		0.58	0.017		0.023
D	5.90		6.30	0.232		0.248
D1	5.30REF			0.209REF		
E	6.40		6.80	0.252		0.268
E1	4.63			0.182		
G	4.47		4.67	0.176		0.184
H	9.50		10.70	0.374		0.421
L	1.09		1.21	0.043		0.048
L2	1.35		1.65	0.053		0.065
V1		7°			7°	
V2		0°	6°	0°		6°

Reel Specification-TO-252

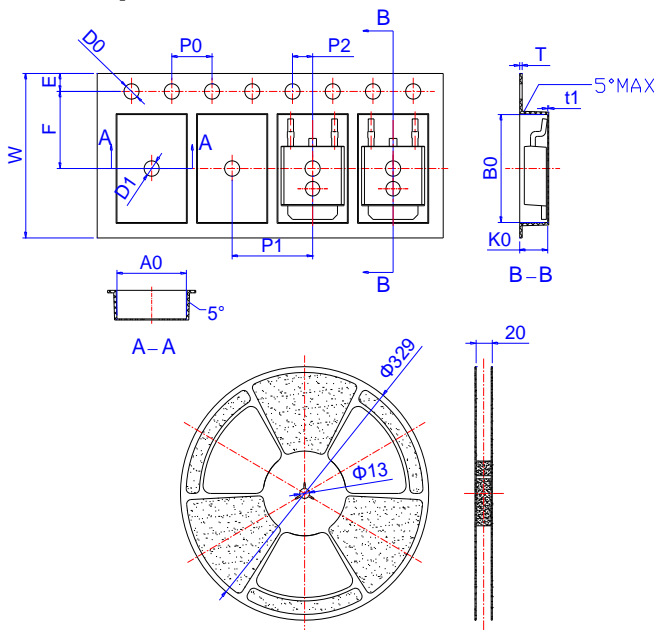

Ref.	Dimensions					
	Millimeters			Inches		
	Min.	Typ.	Max.	Min.	Typ.	Max.
W	15.90	16.00	16.10	0.626	0.630	0.634
E	1.65	1.75	1.85	0.065	0.069	0.073
F	7.40	7.50	7.60	0.291	0.295	0.299
D0	1.40	1.50	1.60	0.055	0.059	0.063
D1	1.40	1.50	1.60	0.055	0.059	0.063
P0	3.90	4.00	4.10	0.154	0.157	0.161
P1	7.90	8.00	8.10	0.311	0.315	0.319
P2	1.90	2.00	2.10	0.075	0.079	0.083
A0	6.85	6.90	7.00	0.270	0.271	0.276
B0	10.45	10.50	10.60	0.411	0.413	0.417
K0	2.68	2.78	2.88	0.105	0.109	0.113
T	0.24		0.27	0.009		0.011
t1	0.10			0.004		
10P0	39.80	40.00	40.20	1.567	1.575	1.583

Shanghai Leiditech Electronic Co.,Ltd
 Email: sale1@leiditech.com
 Tel : +86- 021 50828806
 Fax : +86- 021 50477059