

LMAK12N10 use advanced technology to provide low RDS(ON), low gate charge, fast switching and excellent avalanche characteristics.

This device is specially designed to get better ruggedness and suitable to use in

Features

Low RDS(on) & FOM

Extremely low switching loss

Excellent stability and uniformity of Invertors

Applications

Consumer electronic power supply

Motor control

Synchronous-rectification

Isolated DC

Synchronous-rectification applications

Dimensions TO-252

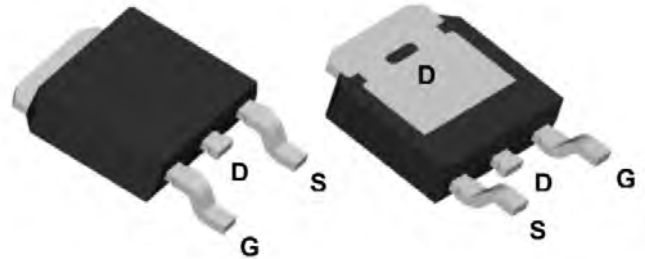

Pin Configuration

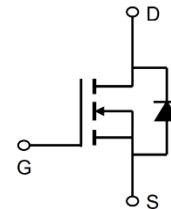

Package Marking and Ordering Information

Product ID	Pack	Marking	Qty(PCS)
LMAK12N10	TO-252	APG12N10D XXX YYYY	2500

Absolute Maximum Ratings at $T_j=25^{\circ}\text{C}$ unless otherwise noted

Parameter	Symbol	Value	Unit
Drain source voltage	VDS	100	V
Gate source voltage	VGS	± 20	V
Continuous drain current ¹⁾ , $T_c=25^{\circ}\text{C}$	I _D	12	A
Pulsed drain current ²⁾ , $T_c=25^{\circ}\text{C}$	I _D , pulse	24	A
Power dissipation ³⁾ , $T_c=25^{\circ}\text{C}$	P _D	17	W
Single pulsed avalanche energy ⁵⁾	EAS	1.2	mJ
Operation and storage temperature	T _{stg} , T _j	-55 to 150	$^{\circ}\text{C}$
Thermal resistance, junction-case	R θ JC	7.4	$^{\circ}\text{C}/\text{W}$
Thermal resistance, junction-ambient ⁴⁾	R θ JA	62	$^{\circ}\text{C}/\text{W}$

Electrical Characteristics at $T_j=25\text{ }^\circ\text{C}$ unless otherwise specified

Symbol	Parameter	Test condition	Min.	Typ.	Max.	Unit	
BV_{DSS}	Drain-source breakdown voltage	$V_{GS}=0\text{ V}, I_D=250\text{ }\mu\text{A}$	100	111		V	
$V_{GS(th)}$	Gate threshold voltage	$V_{DS}=V_{GS}, I_D=250\text{ }\mu\text{A}$	1.2	2.0	2.5	V	
$R_{DS(on)}$	Drain-source on-state resistance	$V_{GS}=10\text{ V}, I_D=5\text{ A}$		105	125	m Ω	
$R_{DS(on)}$	Drain-source on-state resistance	$V_{GS}=4.5\text{ V}, I_D=3\text{ A}$		115	145	m Ω	
I_{GSS}	Gate-source leakage current	$V_{GS}=20\text{ V}$			100	nA	
		$V_{GS}=-20\text{ V}$			-100		
I_{DSS}	Drain-source leakage current	$V_{DS}=100\text{ V}, V_{GS}=0\text{ V}$			1	μA	
C_{iss}	Input capacitance	$V_{GS}=0\text{ V},$ $V_{DS}=50\text{ V},$ $f=100\text{ kHz}$		206.1		pF	
C_{oss}	Output capacitance			28.9		pF	
C_{rss}	Reverse transfer capacitance			1.4		pF	
$t_{d(on)}$	Turn-on delay time			14.7		ns	
t_r	Rise time	$V_{GS}=10\text{ V},$ $V_{DS}=50\text{ V},$ $R_G=2\text{ }\Omega,$ $I_D=5\text{ A}$		3.5		ns	
$t_{d(off)}$	Turn-off delay time			20.9		ns	
t_f	Fall time			2.7		ns	
Q_g	Total gate charge			4.3		nC	
Q_{gs}	Gate-source charge	$I_D=5\text{ A},$ $V_{DS}=50\text{ V},$ $V_{GS}=10\text{ V}$		1.5		nC	
Q_{gd}	Gate-drain charge			1.1		nC	
$V_{plateau}$	Gate plateau voltage			5.0		V	
I_S	Diode forward current					7	A
I_{SP}	Pulsed source current	$V_{GS}<V_{th}$			21		
V_{SD}	Diode forward voltage	$I_S=7\text{ A}, V_{GS}=0\text{ V}$			1.0	V	
t_{rr}	Reverse recovery time	$I_S=5\text{ A}, di/dt=100$		32.1		ns	
Q_{rr}	Reverse recovery charge				39.4		nC
I_{rrm}	Peak reverse recovery current		$\text{A}/\mu\text{s}$		2.1		A

Note

- 1) Calculated continuous current based on maximum allowable junction temperature.
- 2) Repetitive rating; pulse width limited by max. junction temperature.
- 3) P_d is based on max. junction temperature, using junction-case thermal resistance.
- 4) The value of $R_{\theta JA}$ is measured with the device mounted on 1 in 2 FR-4 board with 2oz. Copper, in a still air environment with $T_a=25\text{ }^\circ\text{C}$.
- 5) $V_{DD}=50\text{ V}, R_G=50\text{ }\Omega, L=0.3\text{ mH}$, starting $T_j=25\text{ }^\circ\text{C}$.

Electrical Characteristics Diagrams

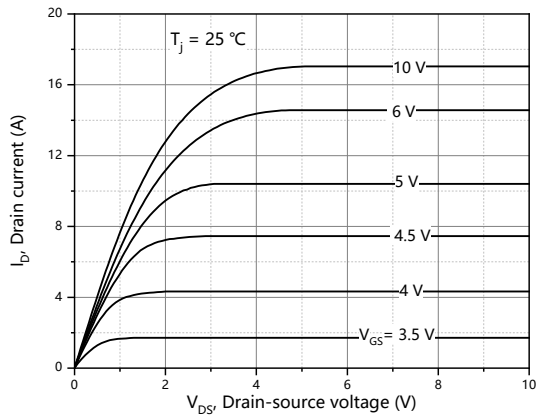

Figure 1, Typ. output characteristics

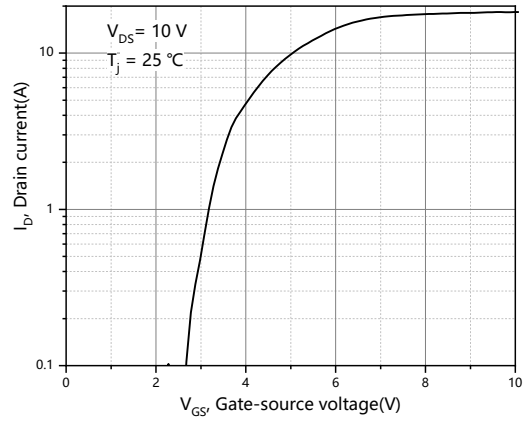

Figure 2, Typ. transfer characteristics

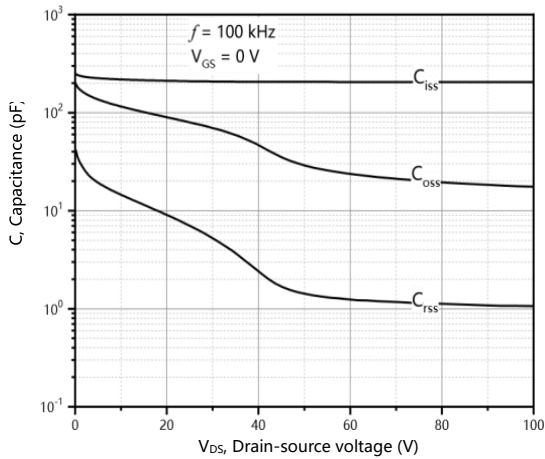

Figure 3, Typ. capacitances

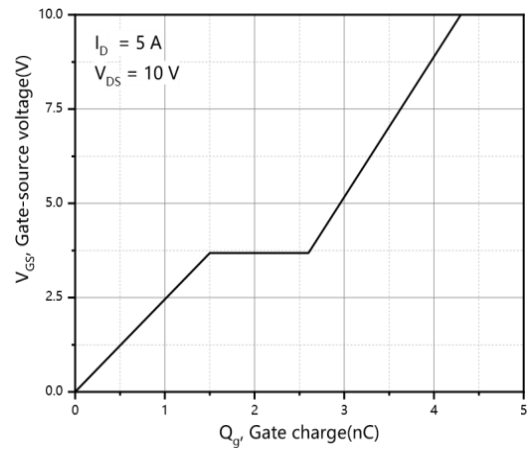

Figure 4, Typ. gate charge

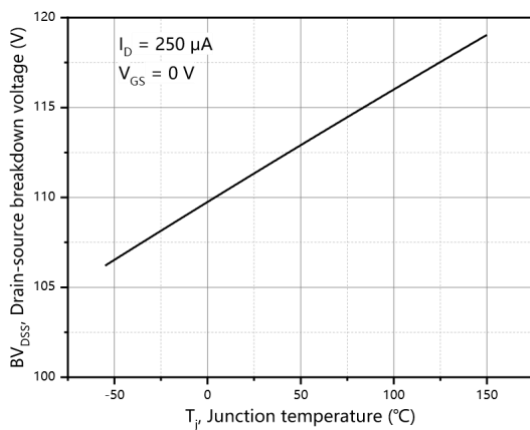

Figure 5, Drain-source breakdown voltage

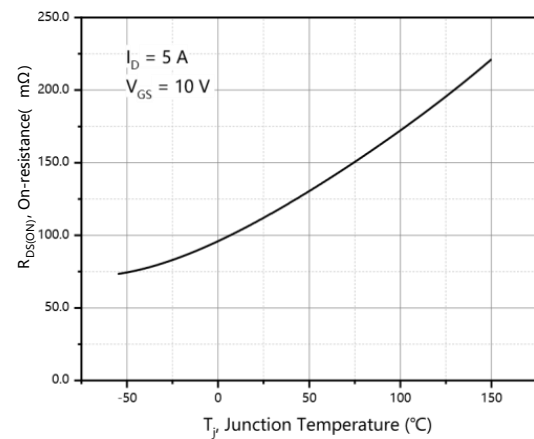

Figure 6, Drain-source on-state resistance

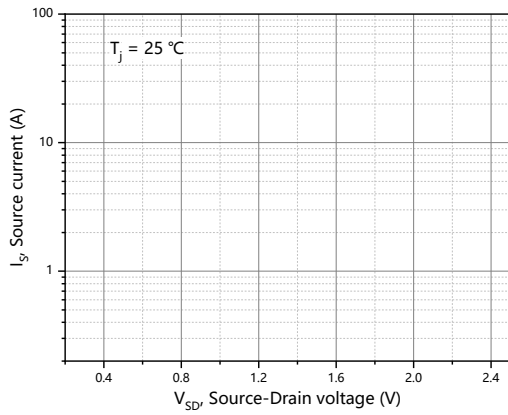

Figure 7, Forward characteristic of body diode

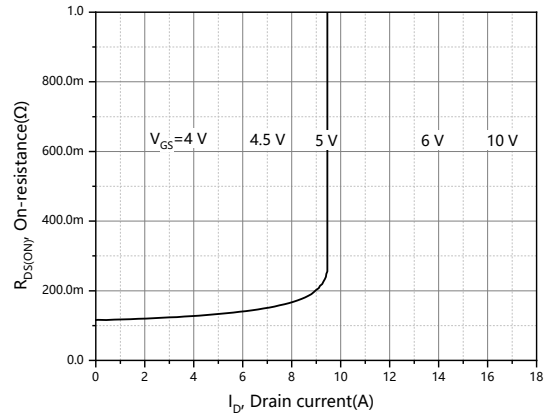

Figure 8, Drain-source on-state resistance

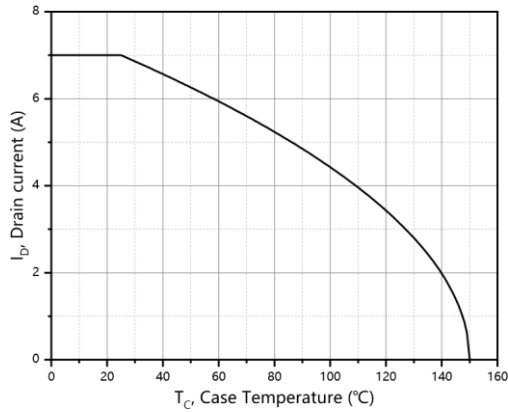

Figure 9, Drain current

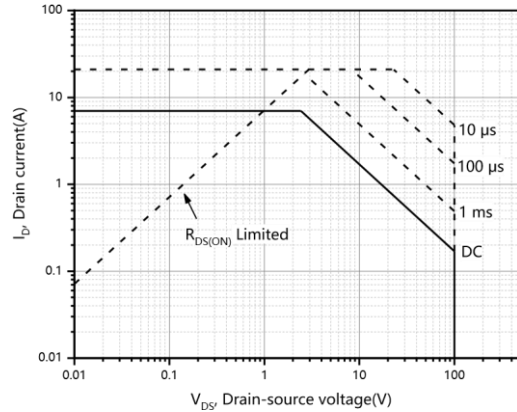

Figure 10, Safe operation area $T_C=25\text{ }^\circ\text{C}$

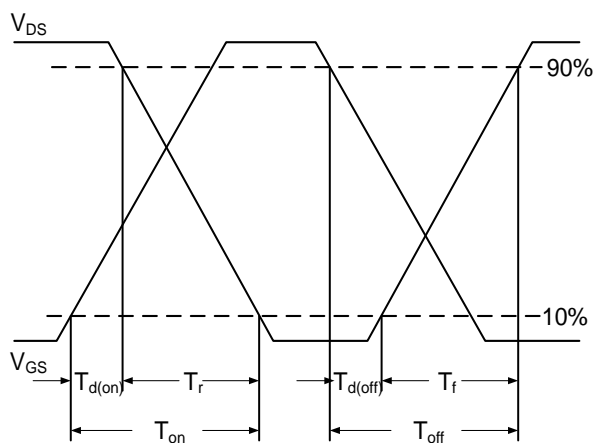

Fig.11 Switching Time Waveform

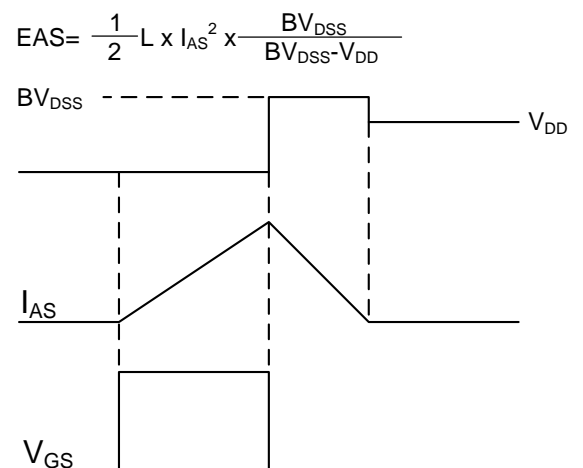
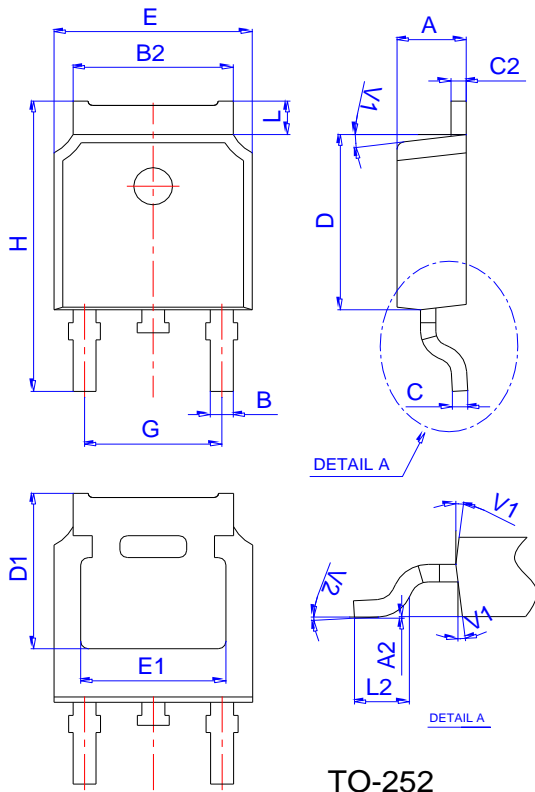

Fig.12 Unclamped Inductive Switching Waveform

Package Mechanical Data-TO-252



Ref.	Dimensions					
	Millimeters			Inches		
	Min.	Typ.	Max.	Min.	Typ.	Max.
A	2.10		2.50	0.083		0.098
A2	0		0.10	0		0.004
B	0.66		0.86	0.026		0.034
B2	5.18		5.48	0.202		0.216
C	0.40		0.60	0.016		0.024
C2	0.44		0.58	0.017		0.023
D	5.90		6.30	0.232		0.248
D1	5.30REF			0.209REF		
E	6.40		6.80	0.252		0.268
E1	4.63			0.182		
G	4.47		4.67	0.176		0.184
H	9.50		10.70	0.374		0.421
L	1.09		1.21	0.043		0.048
L2	1.35		1.65	0.053		0.065
V1		7°			7°	
V2	0°		6°	0°		6°

Reel Specification-TO-252

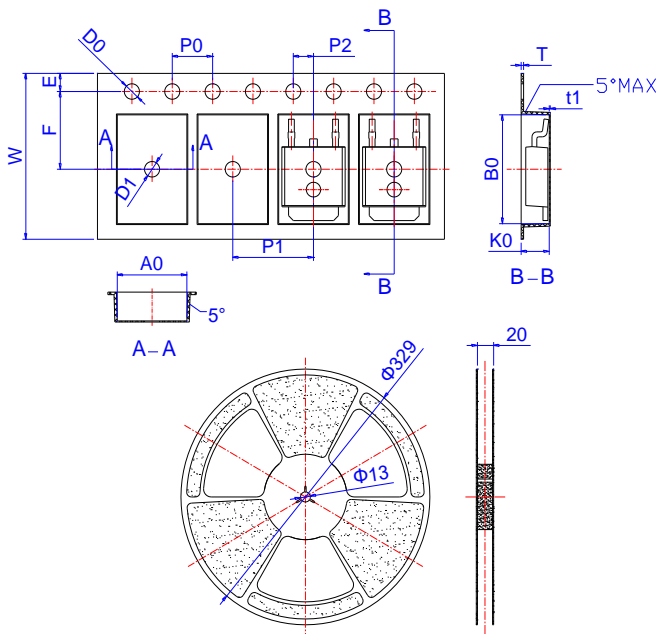

Ref.	Dimensions					
	Millimeters			Inches		
	Min.	Typ.	Max.	Min.	Typ.	Max.
W	15.90	16.00	16.10	0.626	0.630	0.634
E	1.65	1.75	1.85	0.065	0.069	0.073
F	7.40	7.50	7.60	0.291	0.295	0.299
D0	1.40	1.50	1.60	0.055	0.059	0.063
D1	1.40	1.50	1.60	0.055	0.059	0.063
P0	3.90	4.00	4.10	0.154	0.157	0.161
P1	7.90	8.00	8.10	0.311	0.315	0.319
P2	1.90	2.00	2.10	0.075	0.079	0.083
A0	6.85	6.90	7.00	0.270	0.271	0.276
B0	10.45	10.50	10.60	0.411	0.413	0.417
K0	2.68	2.78	2.88	0.105	0.109	0.113
T	0.24		0.27	0.009		0.011
t1	0.10			0.004		
10P0	39.80	40.00	40.20	1.567	1.575	1.583